

Items Supplied >

- 1 – Fi2000CL Fuel Injection Module
- 5 – Zip Ties 6"
- 1 – Velcro Stripe

Application(s) >

HARLEY SOFTAIL CLOSED LOOP
FLS/FLST
2016 - 2017

Instruction Manual >

92-1624CL

Page 1 of 4

Read all instructions carefully and completely before installing your new Fi2000CL module. It is recommended that a qualified mechanic or technician install this product.

1. Remove the seat and air cleaner assembly, remove both front and rear gas tank mounting bolts. Prop the rear of the gas tank up approximately 2".
2. Locate the factory connector on each fuel injector. Depress the clip on the connector and pull the connector free and move it out of the way, see Figure 1. **Note:** A pair of needle nose pliers and a long flat blade screwdriver helps with this job.
3. Lay the Fi2000 module in the area underneath the seat, do not attach it to the motorcycle, route the injector wire harness forward up the right side of the frame backbone, see Figure 2. The harness can be secured using the existing zinc colored harness retainer. Place the injector harness in the plastic loom tray along the right side of the frame backbone. Route the forward set of connectors to the front injector.
4. Attach the pair of Fi2000 module's injector plugs labeled "FRONT" to the front injector. Take the original H.D. connector and insert the corresponding Fi2000 connector into it, refer to Figure 1.
5. Attach the Fi2000 module's remaining injector plugs labeled "REAR" onto the rear injector. Then take the original H.D. connector and insert the corresponding Fi2000 connector into it, refer to Figure 1.
6. It is now time to install the oxygen (O₂) sensor harnesses. Disconnect ground lead first and then positive lead from battery. Remove the battery for access to the area underneath it and to aid in harness installation. Route the longer O₂ sensor harness down through the front of the battery box opening and out the front right side, Figure 3. Continue to route it to the right rear frame next to the swing arm mount and down past the rear of the transmission, then forward along the lower right frame rail to the voltage regulator.
7. Remove the 2 Allen bolts that secure the voltage regulator bracket to the engine case. Ease the voltage regulator forward just enough to access the front O₂ connector, it is located on the backside of this bracket, see Figure 4. Unplug the connector and then plug the Fi2000 female connector into the original HD male connector as well as the other mating pair of connectors. Reinstall this connection on to the voltage regulator bracket and zip tie the other mating pair to it. Be sure the O₂ sensor harness exits the right side, when securing the voltage regulator back on to the engine case. Secure the Fi2000 O₂ harness to the lower right frame rail in the locations shown in Figure 5.
8. Route the shorter Fi2000 O₂ sensor harness to the front side of the battery box. Locate the stock rear O₂ sensor connectors and disconnect them, see Figure 6. Mate the corresponding male and female connectors with the Fi2000 O₂ connectors. Secure this harness to an existing harness along the top of the right frame member using one of the supplied zip ties.

DISCLAIMER: NOT LEGAL FOR SALE OR USE IN CALIFORNIA ON ANY POLLUTION CONTROLLED MOTOR VEHICLES.

9. Reinstall the battery, attach the positive lead, and then the negative along with the black ground wire from the Fi2000 tuner, see Figure 2.
10. Before reinstalling the fuel tank bolts and the seat, verify your connections. Remove the door from the Fi2000 box to expose the LED's. The pot settings on the Fi2000 must be set to match the proper intake and exhaust configuration - Refer to Figure 7 and the **Advanced Tuning** section below to determine the proper configuration. Verify the wire connections by (1) turning the ignition on, prior to starting, and see if all three LED's are on steady. If you have no light, your ground connection (BLACK wire) has not made proper contact or the injector connections are not complete. (2) After achieving a steady light from all three LED's, start the motorcycle, wait 15 seconds and let it idle, the green light should now be the only LED on. If all three LED's are still on after start up, verify you have attached the injector connectors correctly. Reattach the door when finished. **Note:** Make sure the ignition is turned off before changing any connection.
11. Remove the backing from the Velcro and attach the Fi2000 as shown in Figure 2.
12. Re-install the fuel tank mount bolts, seat and air cleaner assembly. Tighten all bolts to factory specifications.

ADVANCED TUNING

Your Fi2000 fuel injection module has been tested and preset for best function and rideability on a motorcycle with stock aircleaner and aftermarket performance slip-on mufflers. The Fi2000 does have 3 important adjustments that allow you to tune the module for optimum performance, especially if you have performed other changes to your motorcycle. These adjustments also allow you to resolve drivability issues if our stock settings are not exactly right for your bike. Make sure your motorcycle is up to normal operating temperature (15 minutes of riding should be sufficient) before making any adjustments.

GREEN LED POT (left pot) – With the Closed Loop function of this module you do not need to adjust this setting, leave it at 2.0. Without a closed loop system this adjustment would affect idle and cruise fuel. If you had cruising issues, this is where you would try a different setting. Generally, surging and uneven running while cruising is a lean fuel condition, so adding a small increase in fuel by turning this adjustment clockwise with a small flat blade screwdriver a 1/2 of a position would help. The bike would need to be Test-driven to feel an improvement and only the setting would need to be increased until the surge went away. Also, backfiring or popping on trailing throttle is generally a lean symptom (or an exhaust gasket leak). The same small increases as above would be tried just until the backfiring would disappear.

YELLOW LED POT (middle pot) - this adjustment affects acceleration and power fuel. If you have a hesitation or bogging on acceleration, this is where you would try a different setting. Aftermarket air cleaner assemblies generally lean out fuel mixtures, so try small clockwise increases as above until a smooth acceleration returns.

RED LED POT (right pot) - this adjustment is the top end or power fuel adjustment. Just like the main jet in a carburetor, it starts to control fuel as you demand maximum power from your bike and takes over completely above 4000 R.P.M. As performance gains are added to your motorcycle, such as big bore kits, camshafts, flowed cylinder heads, etc., each component will increase the fuel demand of the system. With the red pot turned to its maximum (10) position, the Fi2000 will cope with nearly 100 R.W. horsepower. You can generally, if you are using quality performance engine upgrades, in a sensible combination equate the numbers evenly from 2 up to 10 based on horsepower gains.

TUNING NOTES

Typically our 2 into 1 exhaust systems require one additional increase, on the yellow and red pots, over slip-ons or staggered duals. On high performance motors, slip-on mufflers do not flow well enough and create fuel setting problems and detonation. The installation of a complete exhaust system is recommended.

These settings have been tested for stock motorcycles that have popular aftermarket slip-on exhaust systems installed. This Fi2000 will also work in combination with an aftermarket air intake system and various complete exhaust systems.

TROUBLE SHOOTING

If you have any problems refer to Step 10 in the main body of the instructions

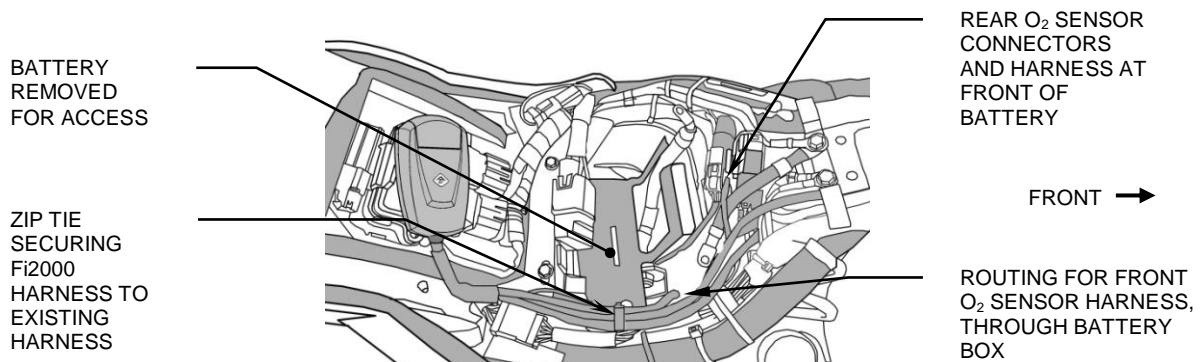
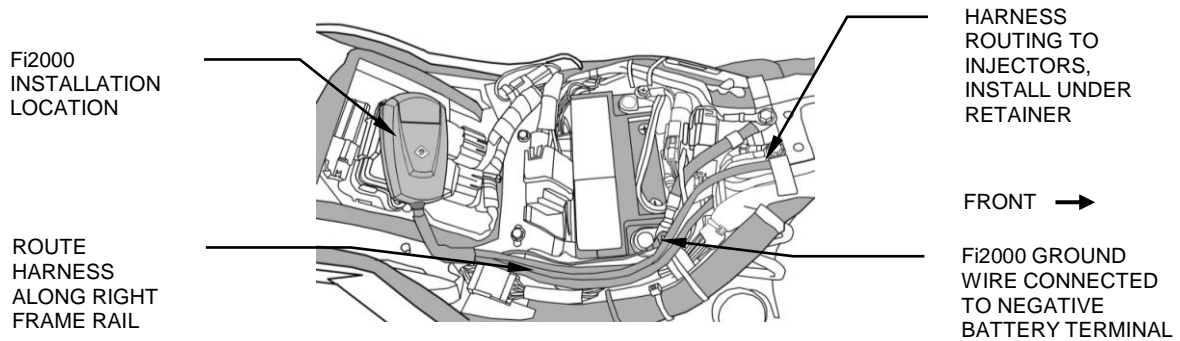
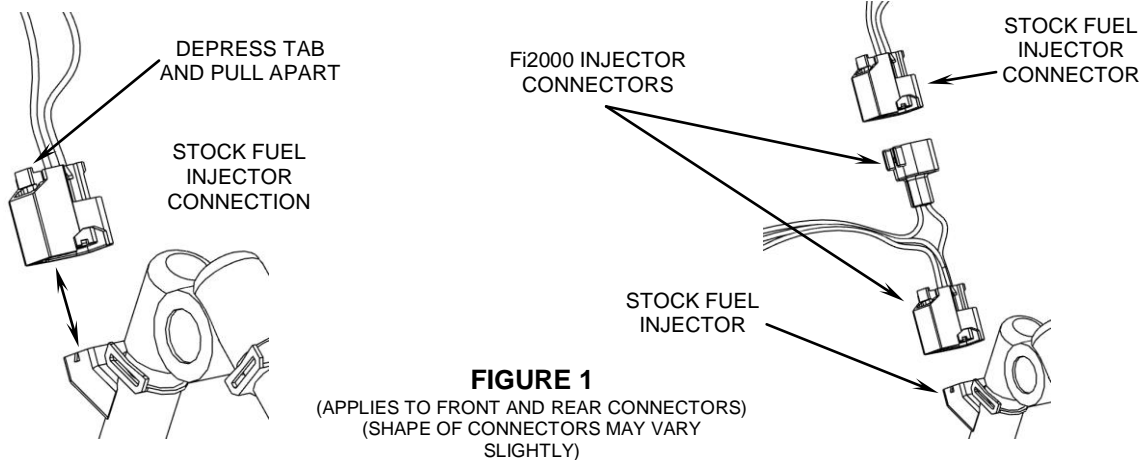

ORIGINAL H.D. FRONT O₂ CONNECTOR WITH Fi2000 CONNECTOR ATTACHED TO VOLTAGE REGULATOR BRACKET

HARNES TO FRONT OXYGEN SENSOR

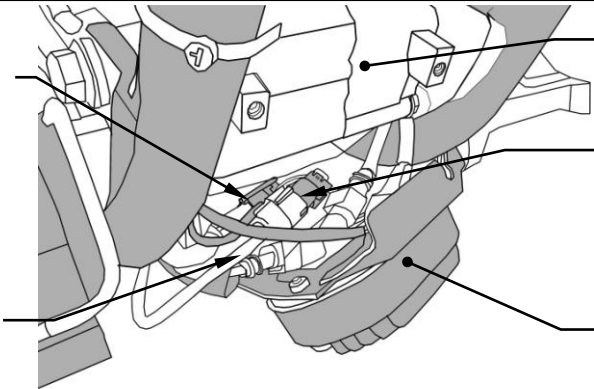

FRONT OF ENGINE CASE

ORIGINAL O₂ SENSOR CONNECTOR TO Fi2000 CONNECTOR, SECURE WITH ZIPTIE TO CONNECTORS ATTACHED TO BRACKET

VOLTAGE REGULATOR UNBOLTED

FIGURE 4

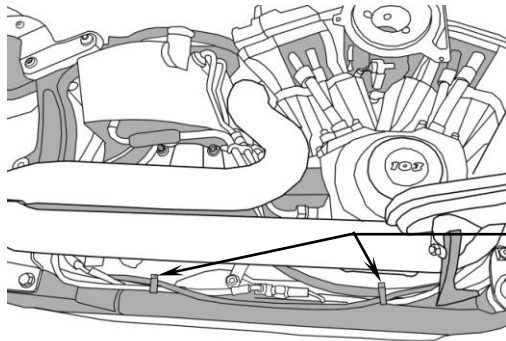

Fi2000 HARNES WITH O₂ SENSOR CONNECTOR

STOCK HARNES WITH Fi2000 FEMALE HARNES CONNECTOR

ZIP TIE LOCATIONS FOR Fi2000 FRONT O₂ SENSOR HARNES

FIGURE 5

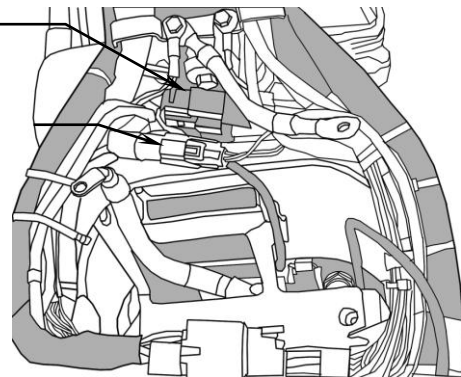

FIGURE 6

Stock w/ Slip-on Mufflers

Default Pot Settings:

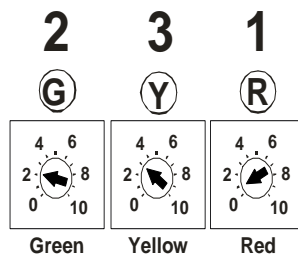

FIGURE 7

Tech Support <https://fi2000.com>