

Items Supplied >

- 1 – Fi2000 Fuel Injection Module
- 3 – Zip Ties 6"
- 1 – Velcro Strip
- 2 – Oxygen Sensor Eliminators

Application(s) >

HARLEY DRESSER
FLHT/ FLHR/ FLTR/ FLHX 2007

Instruction Manual >

92-1608R

Page 1 of 4

ATTENTION: All 2007 Harley DRESSER models manufactured before NOVEMBER 1, 2006 require an ENGINE CONTROL MODULE CALIBRATION update from a Harley Davidson Dealer; please reference Harley Davidson SERVICE BULLETIN M-1186. This Fi2000R is meant to function on all 2007 DRESSER models with this update and all 2007 DRESSER models manufactured after this date which should already have this update installed, check with your local dealer for verification.

Read all instructions carefully and completely before installing your new Fi2000R module. It is recommended that a qualified mechanic or technician install this product.

1. Remove the seat and air cleaner assembly. Remove rear mounting bolt from fuel tank and prop the fuel tank as high as it will comfortably go.
2. Locate the factory connector on each fuel injector. Depress the tab on the connector and pull the connector free from the injector and move it out of the way. **Note:** A pair of needle nose pliers and a long flat blade screwdriver helps with this job, see Figure 1.
3. Lay the Fi2000 module in the open area just behind the fuel tank, Figure 2. By carefully prying the 3 locking tabs, open the right side of the black plastic runner that houses the stock wiring harnesses. Slip the Fi2000 harness into the runner, use the cutout on the left side towards the rear of the runner to feed the harness into it. Route the harness forward about 6 inches and then have it exit at the right side of the runner. Snap the top of the plastic runner back into place.
4. Route the Fi2000 module's forward injector plug, with the red and brown wires behind the existing wires and under the upper motor mount assembly. Connect the Fi2000 gray connector onto the injector and insert the black connector into the original Harley connector, Figure 1.
5. Attach the Fi2000 module's rear female injector plug, with the red and green wires, onto the rear injector. Then take the original female HD connector and insert the corresponding male Fi2000 connector, refer to Figure 1. Tuck both front and rear injector connections out of the way.
6. It is now time to install the oxygen sensor eliminators. At the front of the bike, locate the front O₂ connection. It is ziptied to the front frame cross member. Unplug this connector and insert the supplied O₂ eliminator into the factory connection. This should be possible without cutting either factory ziptie, (unless the O₂ sensors are being removed), see Figure 3.
7. Above the transmission on the right side, you will find the rear O₂ connection. Unplug and insert the other eliminator, ziptie it to the wire harness running down the right side of the frame. If the oxygen sensor is being left in place, then you will have to tuck that wire safely out of the way so it doesn't contact the headpipe, see Figure 3.
8. Feed the Fi2000 black wire under the frame cross member and attach it to the **NEGATIVE** post of the battery. Velcro the module onto the flat area of the frame in the open area, in a position where it will sit flat, see Figure 2.

*** For California riders we offer Air Resources Board approved Fi2000 ARB units with Executive Order number D-633-2. All other Fi2000 models are not legal for street use in California.**

9. Before re-installing the fuel tank, seat and air cleaner assembly, verify your connections. Remove the door from the Fi2000 box to expose the LED's. Verify the wire connections by (1) turning the ignition on, prior to starting, and see if all three LED's are on steady. If you have no light, your ground connection (BLACK wire) has not made proper contact or your front injector connection is not complete. (2) After achieving a steady light from all three LED's, start the motorcycle, wait 15 seconds and let it idle, the green light should now be the only LED on. If all three LED's are still on after start up, verify you have attached the injector connectors correctly. Reattach the door when finished. **Note:** Make sure the ignition is turned off before changing any connection.
10. Re-install the seat, air cleaner assembly and fuel tank mounting bolt.

ADVANCED TUNING

Your Fi2000 fuel injection module has been tested and preset for best function and rideability on a motorcycle with aftermarket air cleaner and an aftermarket performance exhaust. The Fi2000 does however, have 3 important adjustments that allow you to tune the module for optimum performance, especially if you have performed other changes to your motorcycle. These adjustments also allow you to resolve drivability issues if our stock settings are not exactly right for your bike. Make sure your motorcycle is up to normal operating temperature (15 minutes of riding should be sufficient) before making any adjustments. Remove the door to expose the pots shown in Figure 4.

GREEN LED POT (left pot) - this adjustment affects idle and cruise fuel. If you have cruising issues, this is where you would try a different setting. Generally, surging and uneven running while cruising is a lean fuel condition, so try adding a small increase in fuel by turning the adjustment clockwise with a small flat blade screwdriver a 1/2 of a position. Test-drive the bike to feel an improvement and only increase the setting until the surge goes away. Also, backfiring or popping on trailing throttle is generally a lean symptom (or an exhaust gasket leak). Try the same small increases as above just until the backfiring goes away.

YELLOW LED POT (middle pot) - this adjustment affects acceleration and power fuel. If you have a hesitation or bogging on acceleration, this is where you would try a different setting. Aftermarket air cleaner assemblies generally lean out fuel mixtures, so try small clockwise increases as above until a smooth acceleration returns.

RED LED POT (right pot) - this adjustment is the top end or power fuel adjustment. Just like the main jet in a carburetor, it starts to control fuel, as you demand maximum power from your bike and takes over completely above 4000 R.P.M. As performance gains are added to your motorcycle, such as big bore kits, camshafts, flowed cylinder heads, etc., each component will increase the fuel demand of the system. With the red pot turned to its maximum (10) position, the Fi2000 will cope with nearly 100 R.W. horsepower. An all-stock motor will only require a 2 position. You can generally, if you are using quality performance engine upgrades, in a sensible combination equate the numbers evenly from 2 up to 10 based on horsepower gains.

TUNING NOTES

Typically 2 into 1 exhaust systems require one additional position, on the yellow and red pots, over slip-ons or staggered duals.

On high performance motors, slip-on mufflers do not flow well enough and create fuel setting problems and detonation. The installation of a complete exhaust systems is recommended.

TROUBLE SHOOTING

If you have any problems refer to Step 9 in the main body of the instructions.

Tech Support <https://fi2000.com>

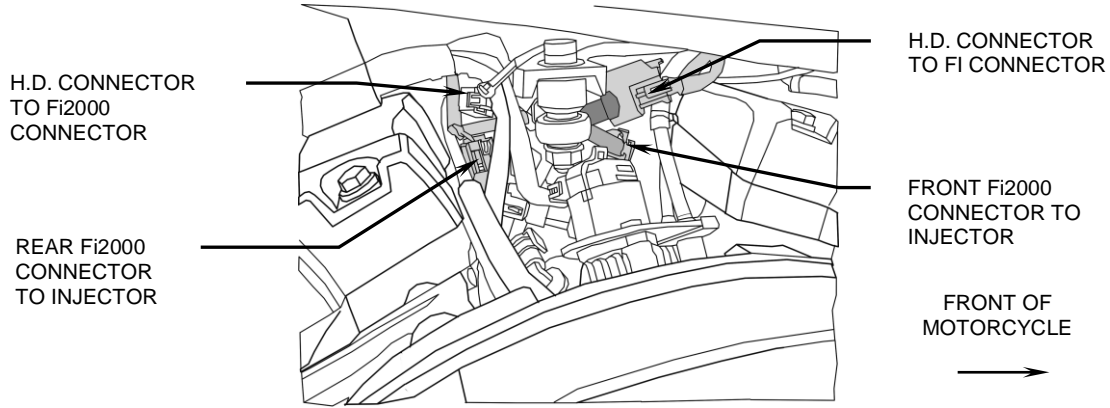

FIGURE 1

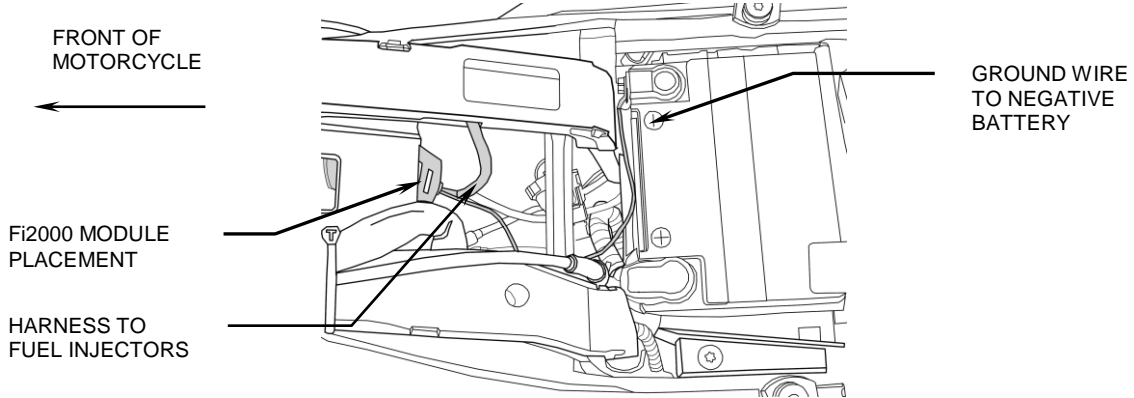

FIGURE 2

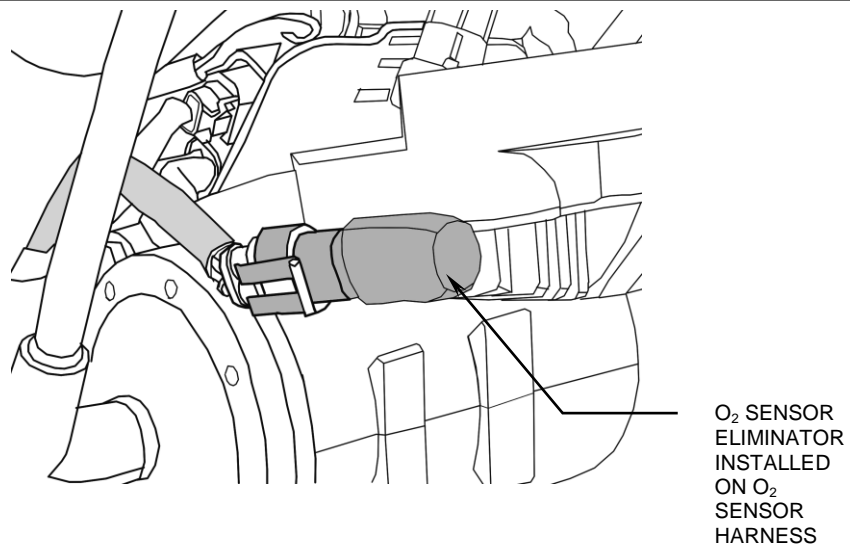
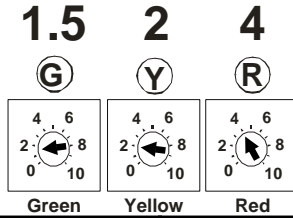

FIGURE 3

(Installation location, may not be exact for this model see location description in instruction text)

FIGURE 4
Fi2000 Pot Settings:
Aftermarket Air Cleaner, Exhaust
Download: From Bulletin: M-1186
Default Pot Settings:



Aftermarket Exhaust Only
Download: From Bulletin: M-1186
Default Pot Settings:

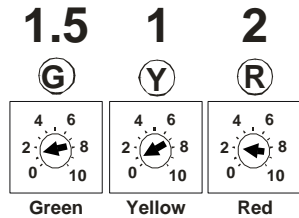

All Stock
Download: From Bulletin: M-1186
Default Pot Settings:

