

Items Supplied >

- 1 – POWRPRO Fuel Injection Module
- 5 – Zip Ties 6"
- 1 – Velcro Stripe

Application(s) >

HARLEY SOFTAIL FXST/FLST 2007
, FLT Police Model 08-09

Instruction Manual >

92-1607B

Page 1 of 3

ATTENTION: All 2007 Harley SOFTAIL models manufactured before NOVEMBER 1, 2006 require an ENGINE CONTROL MODULE CALIBRATION update from a Harley Davidson Dealer; please reference Harley Davidson SERVICE BULLETIN M-1186. This Fi2000 is meant to function on all 2007 SOFTAIL models with this update and all 2007 SOFTAIL models manufactured after this date which should already have this update installed, check with your local dealer for verification.

Read all instructions carefully and completely before installing your new POWRPRO module. It is recommended that a qualified mechanic or technician install this product.

1. Remove the seat and air cleaner assembly, remove both front and rear gas tank mounting bolts. Prop the rear of the gas tank up approximately 2".
2. Locate the factory connector on each fuel injector. Depress the clip on the connector and pull the connector free and move it out of the way. **Note:** A pair of needle nose pliers and a long flat blade screwdriver helps with this job. If you need additional access to the fuel injector connectors, you can remove the Idle Air solenoid by removing the two 5/16" bolts holding it on and loosening the Torx #20 screw on throttle cable bracket. Make sure to use thread-locking compound when refitting the two 5/16" bolts and correctly position the o-ring when reattaching.
3. Lay the Fi2000 module in the area underneath the seat, do not attach it to the motorcycle, route the injector wire harness forward up the right side of the frame backbone, see Figure 1. Route the forward set of connectors under the upper motor mount.
4. Attach one pair of Fi2000 module's injector plugs to the front injector. Take the original female H.D. connector and insert the corresponding Fi2000 male connector into it, refer to Figure 2.
5. Attach the Fi2000 module's remaining female injector plug onto the rear injector. Then take the original female H.D. connector and insert the corresponding male Fi2000 connector, into it, refer to Figure 2.
6. It is now time to install the oxygen sensor harnesses. Remove the battery for access to the area underneath it and to aid in harness installation. To help installation, disconnect square connector at right rear corner of battery to help installation of O₂ sensor harnesses, see Figure 3. Route the two O₂ sensor harnesses down between the main harnesses going to the fuse box and the right rear corner of the frame in the battery area. The longer harness continues down past the rear of the transmission and the shorter harness comes forward under the bottom of the oil tank until it is visible in the cut out area where the battery sits. Unplug the factory O₂ sensor connection and plug in the corresponding male and female connectors.
7. Now route the longer harness up the right side of the frame rail. Following the factory harness and zip tie it to the harness in 3 locations.

DISCLAIMER: NOT LEGAL FOR SALE OR USE IN CALIFORNIA ON ANY POLLUTION CONTROLLED MOTOR VEHICLES.

8. Remove the 2 Allen bolts that secure the voltage regulator bracket to the block, and remove the rectangular cover over the top of this bracket. Ease the voltage regulator forward just enough to access the front O₂ connector. Unplug the connector and then plug the Fi2000 female connector into the original HD male connector. Replace this connection into the voltage regulator bracket and re-assemble onto the bike, making sure the Fi2000 wire exits the top of the cover just like the original wire went in.
9. Now plug the other Fi2000 connector into the oxygen sensor wire and zip tie this connection to the left frame tube in a location that will not allow the wires to touch the exhaust pipe, Figure 4
10. Reinstall the battery, attach the black wire to the negative post of the battery, see Figure 1.
11. Verify that the module has power and connections have been made correctly; watch the clear window on the FI housing and turn "ON" the key ignition and set the handlebar run switch to "ON", confirm that the Red LED turns on. On some models the Red light will turn off after 4-5 seconds as the fuel pump cycles off, which is OK. If you do not see a Red light, it may be necessary to wait for the alarm to reset (if applicable) and try again. Also confirm the side stand is up, bike is in neutral, and clutch is in. Start the bike and confirm the LED remains on solid Red. **NOTE:** Make sure ignition is turned off before attempting to change any Fi2000 harness connections if no Red light is seen. For access to the Blue Tooth Tuning App on the module, please download the Fi2000 App to your smart device, Android 4.3 & later or Apple iOS 5.0 & later operating systems. Once the app is installed, make sure the motorcycle is in neutral and start the engine, use the connect button within the app and the Blue light on the Fi module window will light up during pairing connection and remain solid Blue while paired and connected with respective Android or Apple Device. Once the app has been used and settings saved and disconnected through the app, the Blue light will turn off, and the PowrPro Black will be ready for continued service on the motorcycle.
12. Remove the backing from the Velcro and attach the Fi2000 as shown in Figure 1.
13. Re-install the fuel tank, seat and air cleaner assembly.

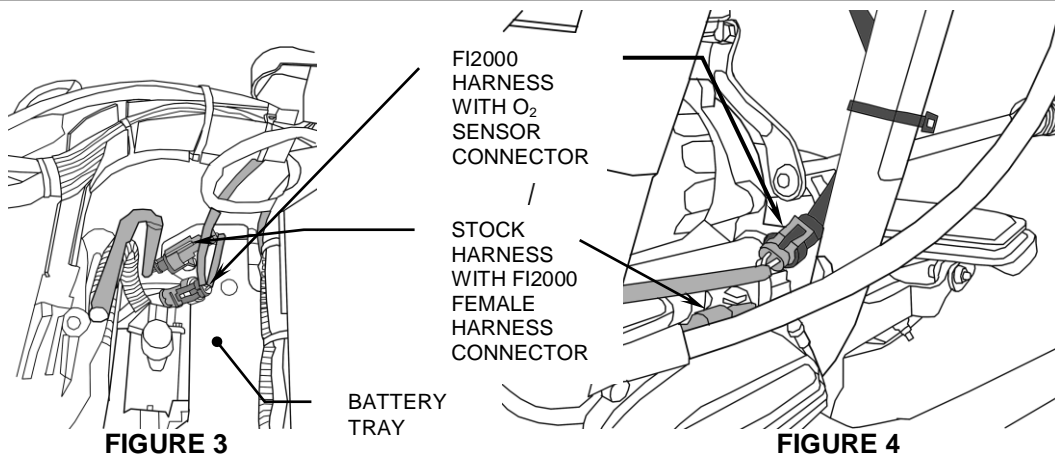
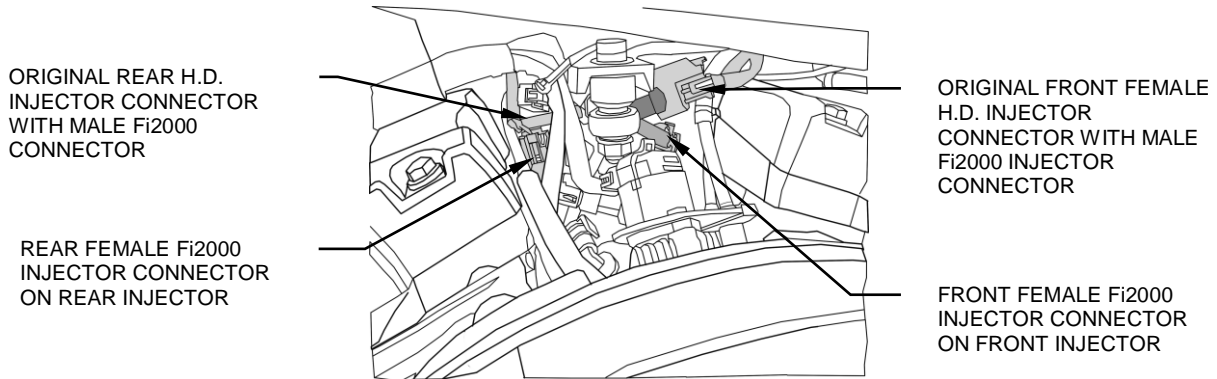
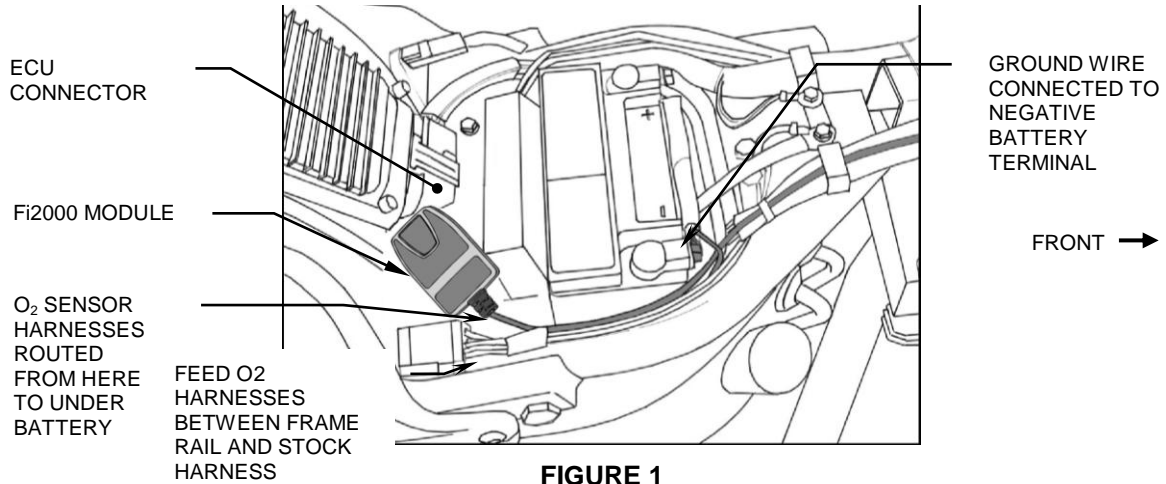

DISCLAIMER: NOT LEGAL FOR SALE OR USE IN CALIFORNIA ON ANY POLLUTION CONTROLLED MOTOR VEHICLES. Tech Support <https://fi2000.com>