

Items Supplied >

- 1 – POWRPRO Fuel Injection Module
- 1 – Velcro Strip
- 1 – Ziptie 8"
- 2 – Ziptie 14"

Application(s) >

HARLEY DRESSER 21-22
FLHT/ FLHR/ FLHX/ FLTRX/ FLTRU/
FLHTCUTG/ FLRT

Instruction Manual >

92-1634B

Page 1 of 3

Read all instructions carefully and completely before installing your new POWRPRO module. It is recommended that a qualified mechanic or technician install this product.

1. It is recommended to have the motorcycle positioned on the kickstand or a motorcycle stand with the handlebars in a straight forward position for accessing components for Powrpro module installation. Remove the right side saddlebag, being careful not to scratch chrome or paint.
2. Remove right side cover and seat to expose engine ECU and oxygen sensor connectors.
3. Disconnect electrical connector and vacuum line on the upper left side of frame behind rear of fuel tank and remove the two bolts securing rear of fuel tank. Pull the vacuum line running down right side of frame upward so it can be removed with tank, see Figure 1. Disconnect the dry-break fuel line from the bottom of the fuel tank by pulling the outer ring upward and then the fuel line / fitting downward. At the front of the fuel tank remove the rubber covers which are installed on the fuel tank's front bolts. With help, remove the bolts and then the entire fuel tank from the motorcycle, set in a secure area to prevent any damage to the tank or paint.
4. Place the Powrpro case and harness on right side of the motorcycle between the large wire harness and ABS control block, under the right side panel area, see Figure 2. Route the main fuel injector harness and ground wire under the right frame rail and upward to under seat area. Open the plastic wire loom sheath by removing cutting the black tape securing it closed. Place the injector harness inside of it, towards the right side, route connectors forward to area between cylinder heads, see Figure 3.
5. Disconnect the stock front female injector connector and mate a pair of the Powrpro connectors to the front injector by installing the Powrpro female connector on to the front injector and stock front female connector to Powrpro male connector. See Figure 4.
6. Mate the other pair of connectors to the rear injector in the same manner as the front injector, See Figure 4.
7. Now locate the oxygen sensor connectors along the right rear frame rail where the right side cover was removed just to the rear of the ABS block. Route the Powrpro oxygen sensor harnesses to this area. Be sure to route them between the large wire harness and ABS control block. Unplug the light grey set of stock connectors and mate the corresponding male and female Powrpro connectors to them. Repeat for black set of oxygen sensor connectors. Make sure all connectors seat firmly, see Figure 5.
8. Attach the ground wire from the Powrpro to the negative battery terminal. Velcro the Powrpro case to the side of the ABS control block, see Figure 2.
9. Secure the oxygen sensor connectors to the frame with the longer supplied zipties, see Figure 5. Use the shorter supplied ziptie to secure the fuel injector harness to the existing wire loom near the front.
10. Close the wire loom sheath and secure to frame using large ziptie. Reinstall fuel tank and reconnect (2) electrical connectors, vacuum line and reroute long vacuum line inside of right frame rail. Reinstall front fuel tank bolts to hold fuel tank in place but do not fully tighten or install rear bolts until all F.I. connections have been verified.

DISCLAIMER: NOT LEGAL FOR SALE OR USE IN CALIFORNIA ON ANY POLLUTION CONTROLLED MOTOR VEHICLES.

12. Verify that the module and connections have been made correctly; watch the clear window on the FI housing and turn "ON" the key ignition and set the handlebar run switch to "ON", confirm that the Red LED turns on. On some models the Red light will turn off after 4-5 seconds as the fuel pump cycles off, which is OK. If you do not see a Red light, it may be necessary to wait for the alarm to reset (if applicable) and try again. Also confirm the side stand is up, bike is in neutral, and clutch is in. Start the bike and confirm the LED remains on solid Red. **NOTE:** Make sure ignition is turned off before attempting to change any POWRPRO harness connections if no Red light is seen. For access to the Blue Tooth Tuning App on the module, please download the PowrPro Black App to your smart device, Android 4.3 & later or Apple iOS 5.0 & later operating systems. Once the app is installed, make sure the motorcycle is in neutral and start the engine, use the connect button within the app and the Blue light on the Fi module window will light up during pairing connection and remain solid Blue while paired and connected with respective Android or Apple Device. Once the app has been used and settings saved and disconnected through the app, the Blue light will turn off, and the PowrPro Black will be ready for continued service on the motorcycle.
13. Once proper Powrpro operation has been verified, reinstall the rear bolts securing the fuel tank, and tighten both front and rear bolts securely. Be sure to reinstall the rubber covers on front bolts. Install the right side cover along with the right saddlebag and seat with screws. Verify once more all hardware has been properly tightened.

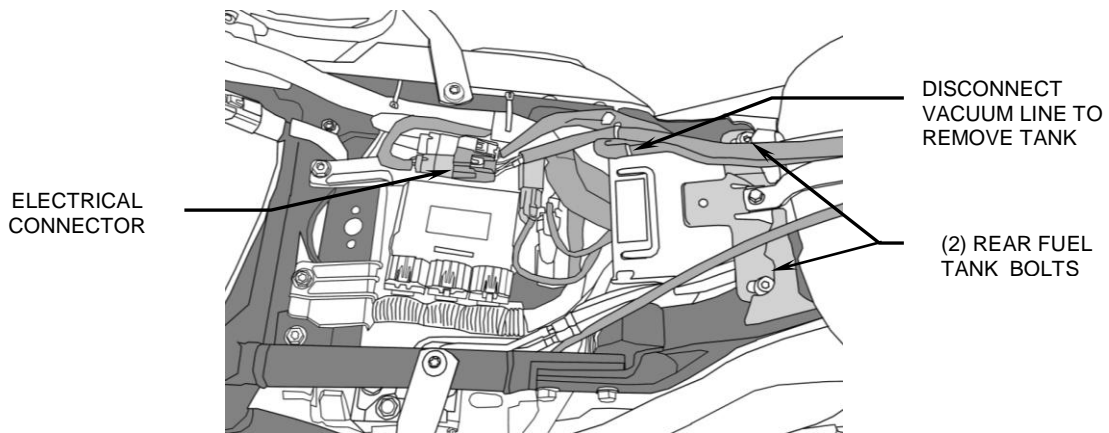

FIGURE 1

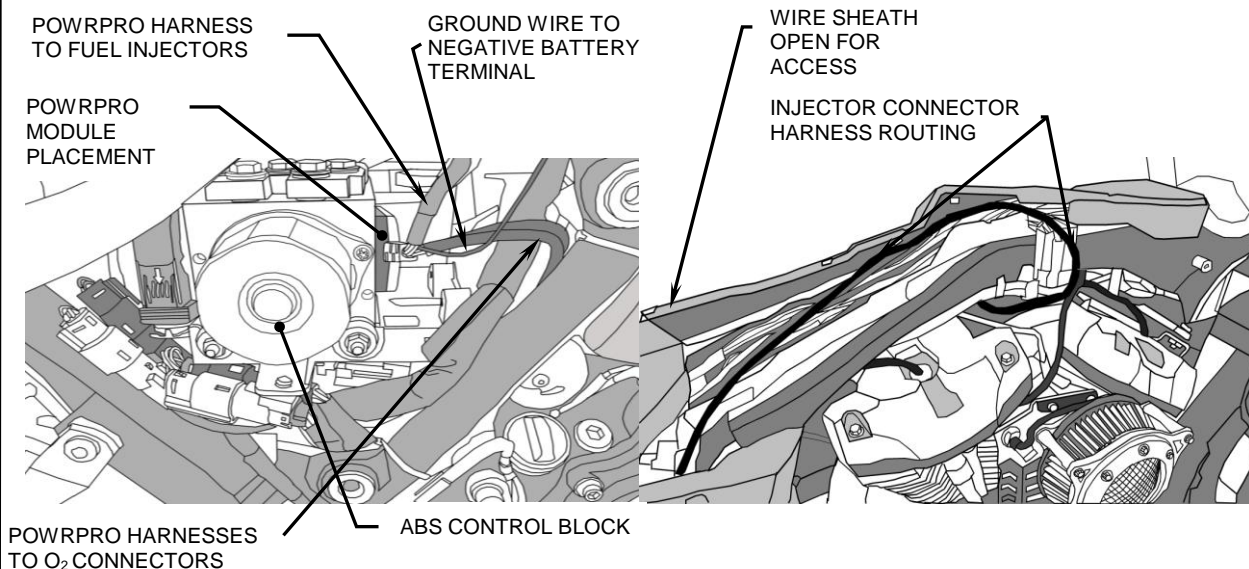

FIGURE 2

FIGURE 3

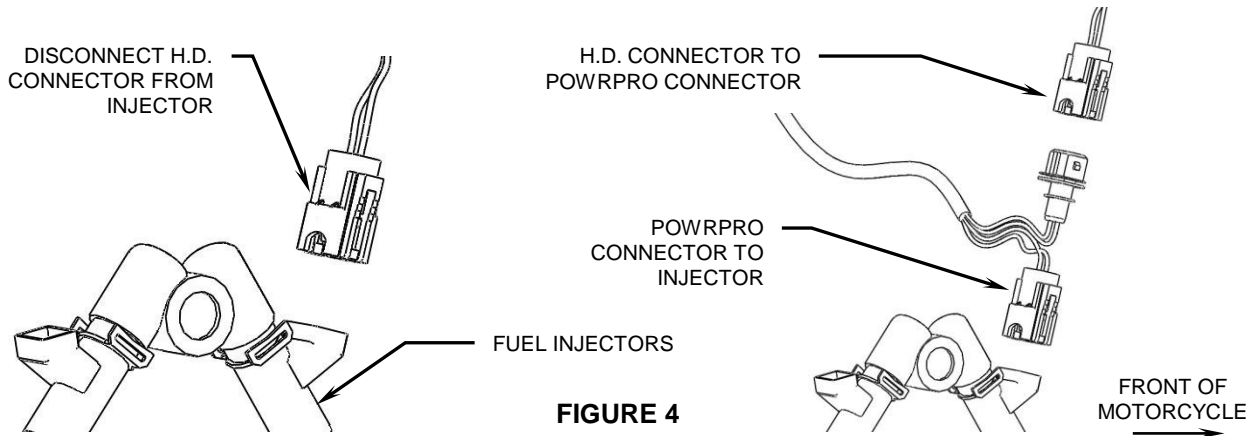

FIGURE 4

(REAR INJECTOR CONNECTORS NOT SHOWN)
 (ACTUAL INJECTORS MAY VARY FROM PICTURE)

STOCK FEMALE REAR O₂ CONNECTOR WITH MALE POWRPRO CONNECTOR

STOCK FEMALE FRONT O₂ CONNECTOR WITH MALE POWRPRO CONNECTOR

SECURE BOTH SETS OF O₂ CONNECTORS TO FRAME RAIL WITH LARGE ZIPTIE IN THIS AREA

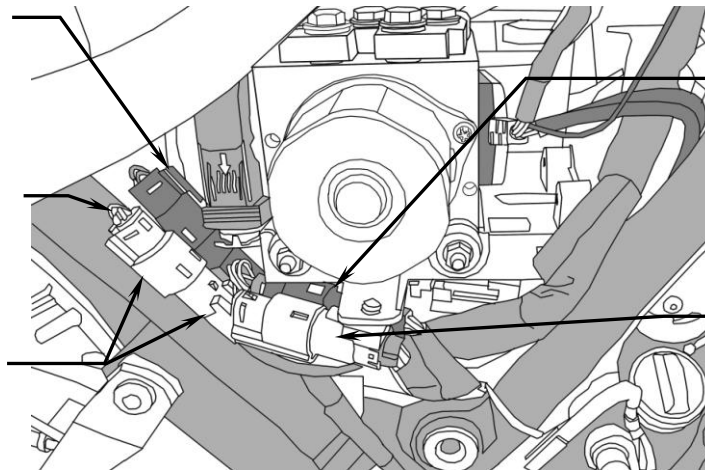

STOCK MALE REAR O₂ CONNECTOR WITH FEMALE POWRPRO CONNECTOR

STOCK MALE FRONT O₂ CONNECTOR WITH FEMALE POWRPRO CONNECTOR

FIGURE 5

DISCLAIMER: NOT LEGAL FOR SALE OR USE IN CALIFORNIA ON ANY POLLUTION CONTROLLED MOTOR VEHICLES. Tech Support <https://fi2000.com>