

## Items Supplied >

- 1 – Powrpro Black Fuel Injection Unit
- 1 – 6" 18# Test Zip Tie
- 1 – Velcro strip

## Application(s) >

KAWASAKI	
VN1700 CLASSIC/LT	09-15
VN1700 NOMAD	09-15
VN1700 VOYAGER	09-15
VN1700 VAQUERO	09-15

## Instruction Manual >

92-1965B

Page 1 of 3

**Read all instructions carefully and completely before installing your new POWRPRO module. It is recommended that a qualified mechanic or technician install this product.**

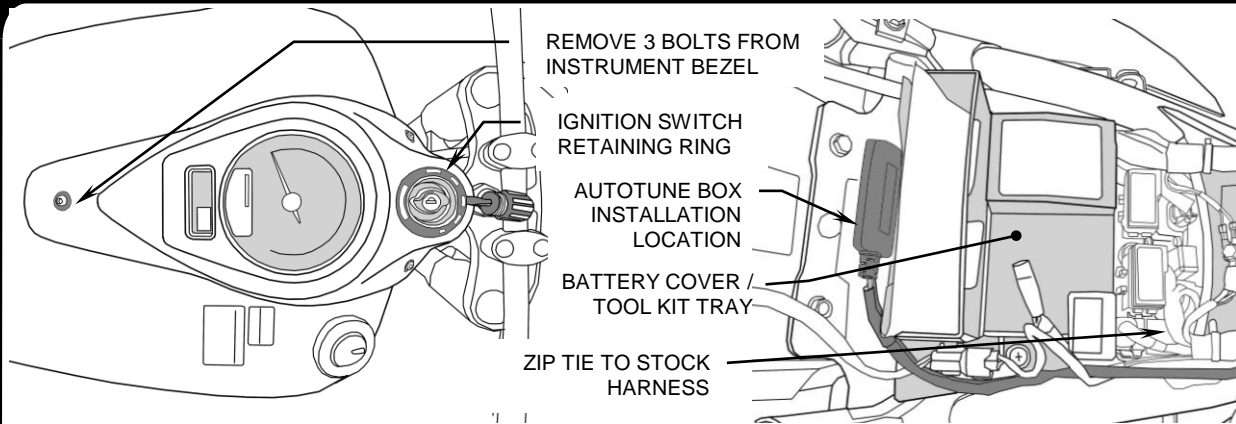
**Before installing it is recommended that the gas tank be low on fuel.**

1. Remove the seat for the passenger and then the seat for the rider.
2. Remove (3) buttonhead screws securing instrument bezel and remove retaining ring around ignition switch, see Figure 1, be sure not to scratch chrome. Unplug large wire harness plug from rear of bezel, and remove bezel to prevent it from scratching fuel tank, when fuel tank will be loosened.
3. Remove two M8 hex bolts and seat-retaining bracket securing rear of fuel tank. Prop fuel tank up approximately 2 inches to gain access to fuel injectors and connectors. Use a long set of offset needle nose pliers to remove front and rear female fuel injector harness connectors. Note which connectors are for front and rear injectors, the front may have a "F" noted on the harness near the female connector.
4. Remove battery cover by removing two Phillips screws, to gain access to battery.
5. Place Fi2000 in under seat area, see Figure 2, and route fuel injector connector harness up right frame rail, continue routing forward along frame rail underneath right side of fuel tank up to fuel injector connectors between cylinder heads. Mate the longer female Fi2000 Connector to the front injector and mate the front original female connector to the male Fi2000 connector, see Figure 3. Mate the shorter female Fi2000 connector to rear injector and mate original rear female connector to shorter male Fi2000 connector.
6. Make sure injector connector harness is routed next to frame rail and install harness in existing rubber harness securing loop along frame rail. Pull extra harness slack towards rear of motorcycle, but not to taut.
7. Now remove screw securing ground wire to battery. Place black ground wire from Fi2000 on top of negative ground wire and reinstall screw, see Figure 4. Make sure ground wire is routed downward in a similar orientation as main ground wire. Reinstall battery cover with 2 screws.
8. Velcro the Fi2000 module to the battery cover / tool kit tray as shown in Figure 2, using supplied Velcro.
9. Lower the fuel tank back into position and reconnect and install instrument bezel. Wait to install bezel screws, retaining ring, seat retaining bracket, bolts, and seat until Fi2000 wire connections and function have been verified.

**DISCLAIMER: NOT LEGAL FOR SALE OR USE IN CALIFORNIA ON ANY POLLUTION CONTROLLED MOTOR VEHICLES.**

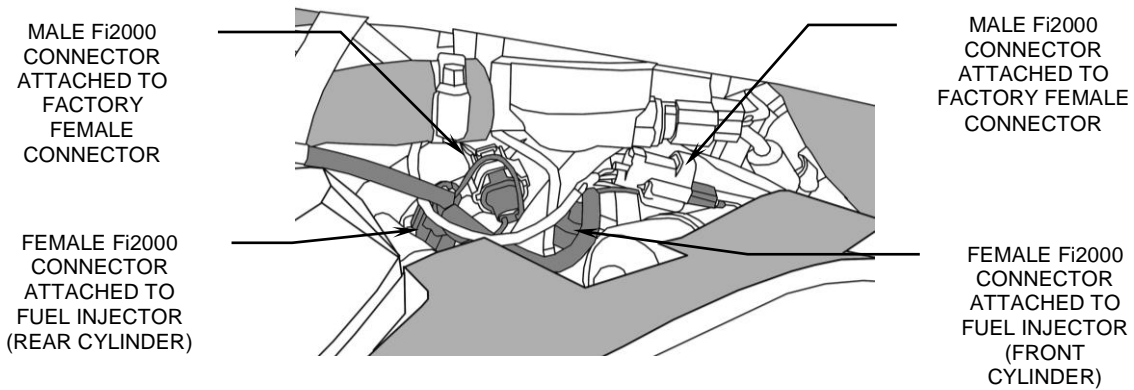
DOCUMENT NO. 0017 REV. A

10. Verify that the module has power and connections have been made correctly; watch the clear window on the FI housing and turn "ON" the key ignition and set the handlebar run switch to "ON", confirm that the Red LED turns on. On some models the Red light will turn off after 4-5 seconds as the fuel pump cycles off, which is OK. If you do not see a Red light, it may be necessary to wait for the alarm to reset (if applicable) and try again. Also confirm the side stand is up, bike is in neutral, and clutch is in. Start the bike and confirm the LED remains on solid Red. **NOTE:** Make sure ignition is turned off before attempting to change any Fi2000 harness connections if no Red light is seen. For access to the Blue Tooth Tuning App on the module, please download the Fi2000 App to your smart device, Android 4.3 & later or Apple iOS 5.0 & later operating systems. Once the app is installed, make sure the motorcycle is in neutral and start the engine, use the connect button within the app and the Blue light on the Fi module window will light up during pairing connection and remain solid Blue while paired and connected with respective Android or Apple Device. Once the app has been used and settings saved and disconnected through the app, the Blue light will turn off, and the PowrPro Black will be ready for continued service on the motorcycle.
11. Reinstall the instrument bezel ignition retaining ring and be sure to align the word "OFF", to the top to allow for proper installation. Reinstall the screws securing the bezel. Reinstall seat bracket along with M8 bolts securing rear of fuel tank. Reinstall rider and passenger seats. Be sure all fasteners have been properly tightened.

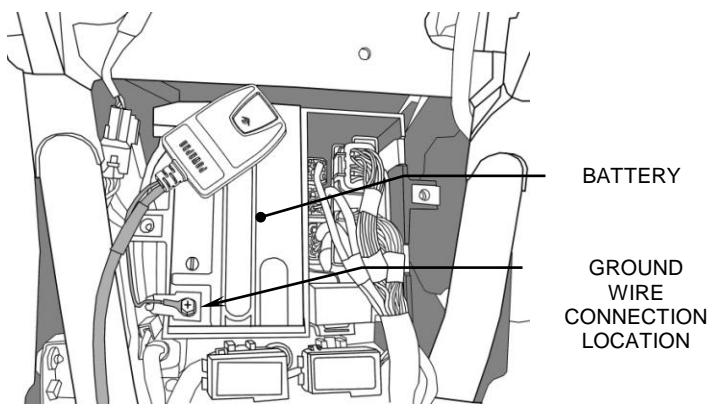


**FIGURE 1: INSTRUMENT BEZEL REMOVAL**

**FIGURE 2: Fi2000 LOCATION**



**FIGURE 3: Fi2000 ECU INSTALLATION LOCATION**



**FIGURE 4  
GROUND WIRE INSTALLATION**

**DISCLAIMER:** NOT LEGAL FOR SALE OR USE IN CALIFORNIA ON ANY POLLUTION CONTROLLED MOTOR VEHICLES. Tech Support <https://fi2000.com>