

COBRA

Items Supplied >

- 1 – Powrpro Black Fuel Injection Module
- 1 – Zip Tie 6"
- 1 – Velcro Strip

Application(s) >

Suzuki Boulevard C50 (49 State Models)
2009-2021

Instruction Manual >

92-1827B

Page 1 of 2

Read all instructions carefully and completely before installing your new POWRPRO module. It is recommended that a qualified mechanic or technician install this product.

1. Remove both seats; remove the instrument bezel. Next, be sure that the fuel tank is low on fuel. Remove the fuel tank by removing the bolts and lifting the tank enough to gain access to the 4 pin brown wire connector and dry brake fuel line. Unplug the wire connector by pressing the tab inwards. Disconnect the dry brake fuel line by depressing the two gray tabs. Remove the fuel tank.
2. Temporarily position the Fi2000 module by the battery, and route the wire harness forward into the notch in plastic cover, see Figure 1. Continue routing the harness under the frame at the rear of the fuel tank, and continue it up past the left side of the throttle body assembly.
3. Locate the MAP sensor on the left side of the air intake boot. Slide the steel sensor mount out of the intake boot to allow access to the front fuel injector, underneath the boot, see Figure 2.
4. Disconnect the stock front injector connector by pressing on the tab at the rear of the connector. On the Fi2000 harness locate the longer set of connectors. Now connect the female Fi2000 matching connector to the injector and then connect the stock female connector to the corresponding male Fi2000 connector. Reinstall the map sensor. Route the Fi2000 harness so that it is fixed in the retaining hook near the air intake boot, to keep the harness clear of the throttle linkage, see Figure 2.
5. Locate the rear injector on the throttle body housing disconnect it and mate the corresponding male connector from the rear portion of the Fi2000 harness to it, see Figure 3. Mate the Female Fi2000 connector onto the injector. When finished, make sure the wire harness does not foul any throttle cable linkage. Install the zip tie to secure the harness as shown in Figure 1. Reinstall the fuel tank by reconnecting the brown four-pin connector and dry brake fuel line to the fuel tank.
6. Connect the Fi2000 ground wire (black), to the negative post of the battery and attach the Fi2000 module to the top of the plastic panel with the supplied Velcro, see Figure 1. Before reinstalling the seats verify all connections are made properly.
7. Verify that the module has power and connections have been made correctly; watch the clear window on the FI housing and turn "ON" the key ignition and set the handlebar run switch to "ON", confirm that the Red LED turns on. On some models the Red light will turn off after 4-5 seconds as the fuel pump cycles off, which is OK. If you do not see a Red light, it may be necessary to wait for the alarm to reset (if applicable) and try again. Also confirm the side stand is up, bike is in neutral, and clutch is in. Start the bike and confirm the LED remains on solid Red. **NOTE:** Make sure ignition is turned off before attempting to change any Fi2000 harness connections if no Red light is seen. For access to the Blue Tooth Tuning App on the module, please download the Fi2000 App to your smart device, Android 4.3 & later or Apple iOS 5.0 & later operating systems. Once the app is installed, make sure the motorcycle is in neutral and start the engine, use the connect button within the app and the Blue light on the Fi module window will light up during pairing connection and remain solid Blue while paired and connected with respective Android or Apple Device. Once the app has been used and settings saved and disconnected through the app, the Blue light will turn off, and the PowrPro Black will be ready for continued service on the motorcycle.

DISCLAIMER: NOT LEGAL FOR SALE OR USE IN CALIFORNIA ON ANY POLLUTION CONTROLLED MOTOR VEHICLES. Tech Support <https://fi2000.com>

DOCUMENT NO. 0017 REV. A

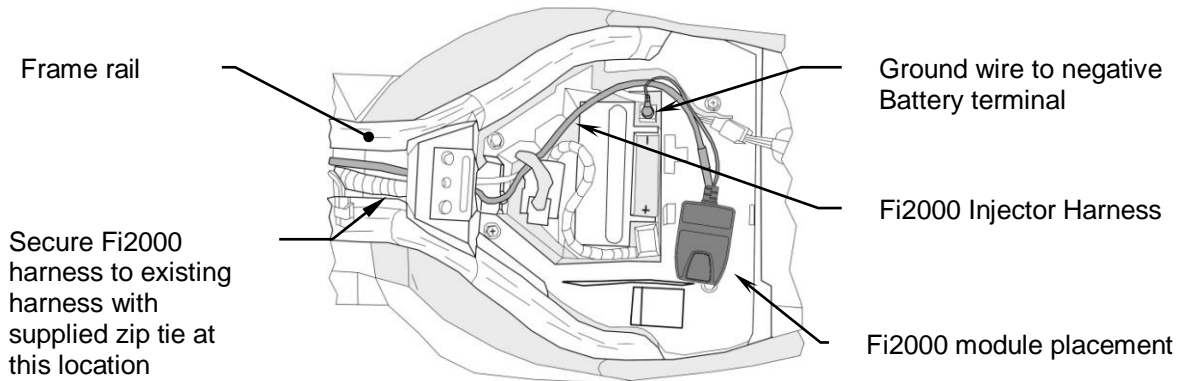

FIGURE 1

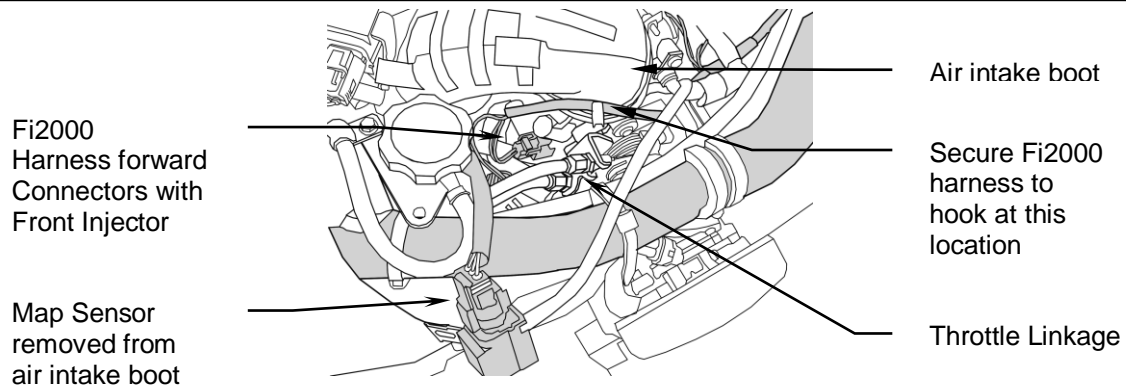

FIGURE 2

(Fuel tank removed for access to injector connector locations)

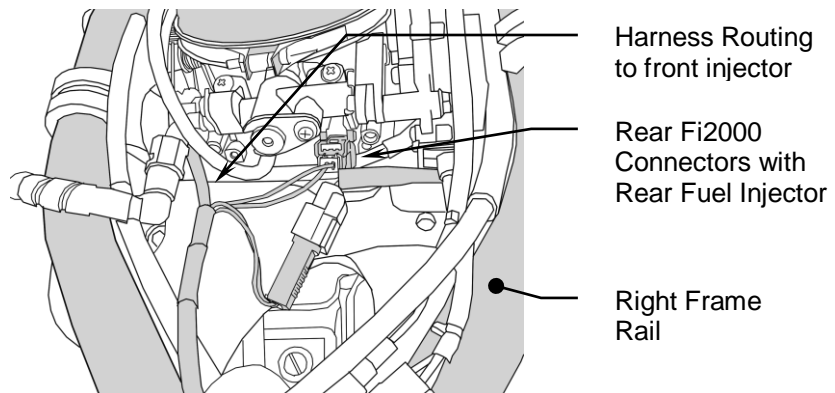

FIGURE 3

(Fuel tank removed for access to injector connector locations)