

## Items Supplied >

- 1 – Powrpro Black Fuel Injection Module
- 2 – Zip Ties, (1): 3/32" x 6"; & (1): 3/16" x 8"
- 1 – Velcro Strip

## Application(s) >

Suzuki Boulevard C90

05-09

## Instruction Manual >

92-1840B

Page 1 of 2

**Read all instructions carefully and completely before installing your new POWRPRO module.**

**It is recommended that a qualified mechanic or technician install this product.**

**Before installing it is recommended that the gas tank be low on fuel.**

1. Remove both seats; Open the gas cap access panel, and remove the (4) upper and (2) lower allen head bolts and the (3) philips screws that surround the gas cap. Temporarily remove the gas cap.
2. Remove the (2) front console allen head screws, lift the console enough to unplug the wiring from the console, and then remove it. Remove the two front steering neck covers, and then remove both dummy gas tank sides.
3. Loosen both air box clamps; unplug the temp sensor from the front right side by pressing the green tab inward, lift the air box up at the front enough to unplug the breather hose. Disconnect the lower breather hose and lift the air box away.
4. Locate the rear injector on the right side, under the frame cross rail. Feed the wire harness of the Fi2000 from the forward left side, back and over the throttle cables and then around the throttle body. Unplug the black connector from the rear fuel injector by squeezing both sides of the connector. Plug the longest matching Fi2000 connector into the injector, (Fig. 1). Plug the original connector into the corresponding Fi2000 connector, and then tuck this connection back underneath the frame rail.
5. Route the Fi2000 harness between the connectors along the hydraulic clutch line, (black steel tube about 3/16" diameter), and zip tie it so it clears the throttle linkage. Then disconnect the front fuel injector connector and attach the Fi2000 just like the rear, (Fig. 2).
6. Velcro the Fi2000 module to the outside of the factory ECU with the wires pointing downwards, then remove the front bolt of the ignition coil, slip the ground ring of the black wire from the Fi2000 in between the frame and coil spacer, (Fig. 3). Replace and tighten the bolt.
7. Confirm there is no interference of the Fi2000 wiring and throttle linkage, (Fig. 2), then replace the air box with its hoses, and wires. Before reinstalling the remaining bodywork verify all connections, (to do this, the dash must be temporarily plugged in to operate the key.)
8. Verify that the module has power and connections have been made correctly; watch the clear window on the FI housing and turn "ON" the key ignition and set the handlebar run switch to "ON", confirm that the Red LED turns on. On some models the Red light will turn off after 4-5 seconds as the fuel pump cycles off, which is OK. If you do not see a Red light, it may be necessary to wait for the alarm to reset (if applicable) and try again. Also confirm the side stand is up, bike is in neutral, and clutch is in. Start the bike and confirm the LED remains on solid Red. **NOTE:** Make sure ignition is turned off before attempting to change any Fi2000 harness connections if no Red light is seen. For access to the Blue Tooth Tuning App on the module, please download the Fi2000 App to your smart device, Android 4.3 & later or Apple iOS 5.0 & later operating systems. Once the app is installed, make sure the motorcycle is in neutral and start the engine, use the connect button within the app and the Blue light on the Fi module window will light up during pairing connection and remain solid Blue while paired and connected with respective Android or Apple Device. Once the app has been used and settings saved and disconnected through the app, the Blue light will turn off, and the PowrPro Black will be ready for continued service on the motorcycle.

**DISCLAIMER: NOT LEGAL FOR SALE OR USE IN CALIFORNIA ON ANY POLLUTION CONTROLLED MOTOR VEHICLES.**

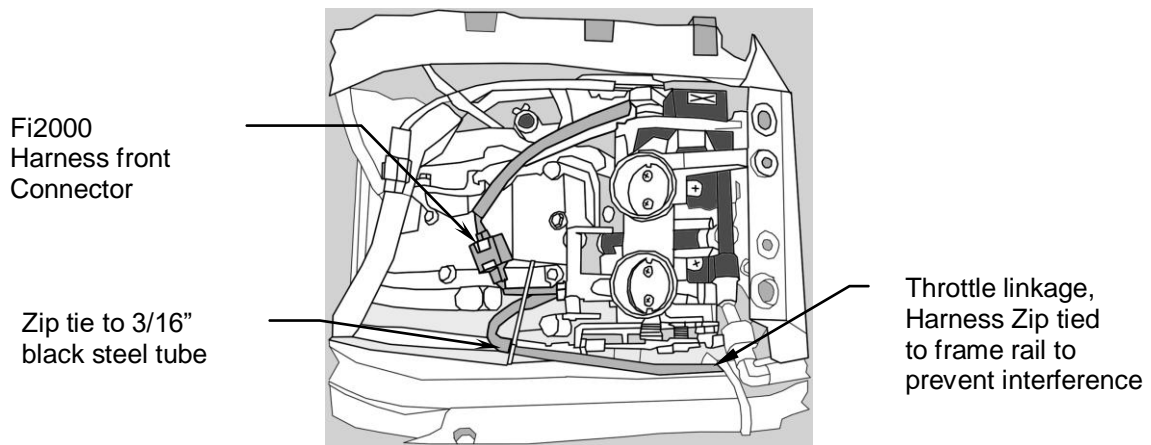
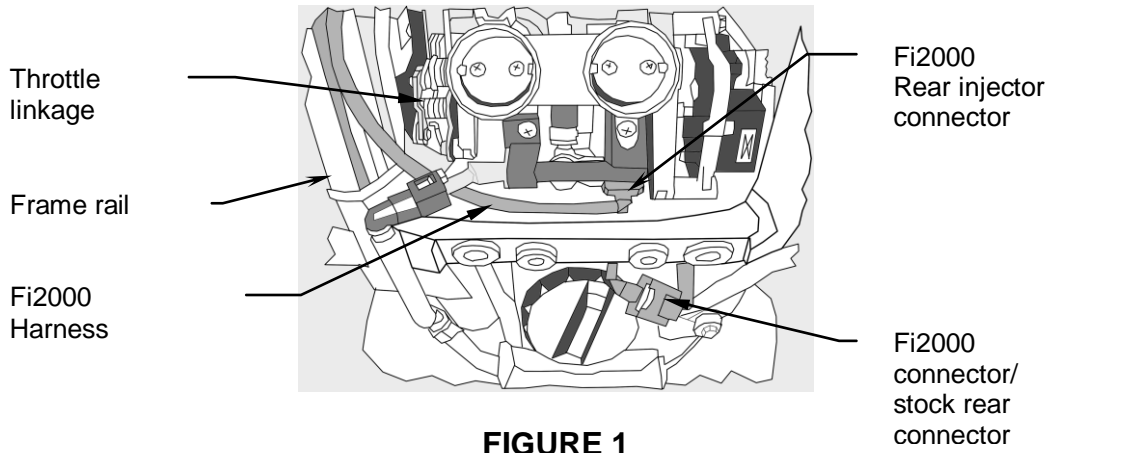

**DISCLAIMER:** NOT LEGAL FOR SALE OR USE IN CALIFORNIA ON ANY POLLUTION CONTROLLED MOTOR VEHICLES. Tech Support <https://fi2000.com>