

Items Supplied >

- 1 – Powrpro Black Fuel Injection Module
- 2 – Zip Tie, 3/16" x 6" Long
- 1 – Zip Tie, 3/16" x 4" Long
- 1 – Velcro Strip

Application(s) >

YAMAHA STRYKER XVS1300 2011-2022

Instruction Manual >

92-1770B

Page 1 of 2

Read all instructions carefully and completely before installing your new POWRPRO module. It is recommended that a qualified mechanic or technician install this product.

Before installing the POWRPRO it is recommended that the gas tank be low on fuel.

1. Remove the seat. Remove the two 12 mm headed bolts securing the rear of the fuel tank, prop the tank up securely to allow access to the fuel injector connectors.
2. Position the Fi2000® module in the area under the seat, then feed the Fi2000 injector harness with the four connectors forward under the seat latch bracket, under the fuel tank and along the upper left side frame rail and to the injector area between front and rear engine cylinders, see Figure 1.
3. Locate the front and rear injectors and remove stock female connector from front injector, see Figure 2. On Fi2000 injector harness use the longer of the two connector pairs and install the Fi2000 female connector onto the front injector. Install the corresponding male Fi2000 connector into the stock front female injector connector. Repeat for rear injector using the short pair of Fi2000 connectors. Be sure female connectors seat properly on injectors and the stock connectors are fully pressed together with the Fi2000 male connectors. Tuck these connectors out of the way and lower the fuel tank. Secure Fi2000 harness to left frame rail with 6" zip tie.
4. Remove the right side cover retained by buttonhead screw and triangular panel below it. Push inward on the center of the plastic peg fastener to remove it as the triangular plastic panel is pulled outward, see Figure 3.
5. Route the second Fi2000 harness with the clear connectors forward under the right side frame rail and forward along front of fuel pump tank, then down to the stock oxygen sensor connectors, see Figure 4. Unplug this connection and then plug in the corresponding Fi2000 connectors into the stock connectors. Coil excess wire harness and secure in loop with supplied 6" zip tie. Replace the triangular cover to hide these connectors. Secure the Fi2000 oxygen sensor harness to the clutch cable sheath using the supplied 4" zip tie.
6. Clean off the top of the fuel pump tank and remove backing from supplied Velcro. Mount the Fi2000 on top of the tank, see Figure 1. Lift up the tool tray / battery cover to access the negative post of the battery. Attach the ground wire from the Fi2000 to the negative post. Reinstall the cover. Before reinstalling the seat, verify Fi2000 harness connections have been made properly.
7. Verify that the module has power and connections have been made correctly; watch the clear window on the FI housing and turn "ON" the key ignition and set the handlebar run switch to "ON", confirm that the Red LED turns on. On some models the Red light will turn off after 4-5 seconds as the fuel pump cycles off, which is OK. If you do not see a Red light, it may be necessary to wait for the alarm to reset (if applicable) and try again. Also confirm the side stand is up, bike is in neutral, and clutch is in. Start the bike and confirm the LED remains on solid Red. **NOTE:** Make sure ignition is turned off before attempting to change any Fi2000 harness connections if no Red light is seen. For access to the Blue Tooth Tuning App on the module, please download the Fi2000 App to your smart device, Android 4.3 & later or Apple iOS 5.0 & later operating systems. Once the app is installed, make sure the motorcycle is in neutral and start the engine, use the connect button within the app and the Blue light on the Fi module window will light up during pairing connection and remain solid Blue while paired and connected with respective Android or Apple Device. Once the app has been used and settings saved and disconnected through the app, the Blue light will turn off, and the PowrPro Black will be ready for continued service on the motorcycle.
8. Reinstall right side cover and triangular plastic cover over oxygen sensor connectors, be sure plastic pin is installed correctly. Lower fuel tank and reinstall 12mm headed bolts securely, reinstall seat.

DISCLAIMER: NOT LEGAL FOR SALE OR USE IN CALIFORNIA ON ANY POLLUTION CONTROLLED MOTOR VEHICLES.

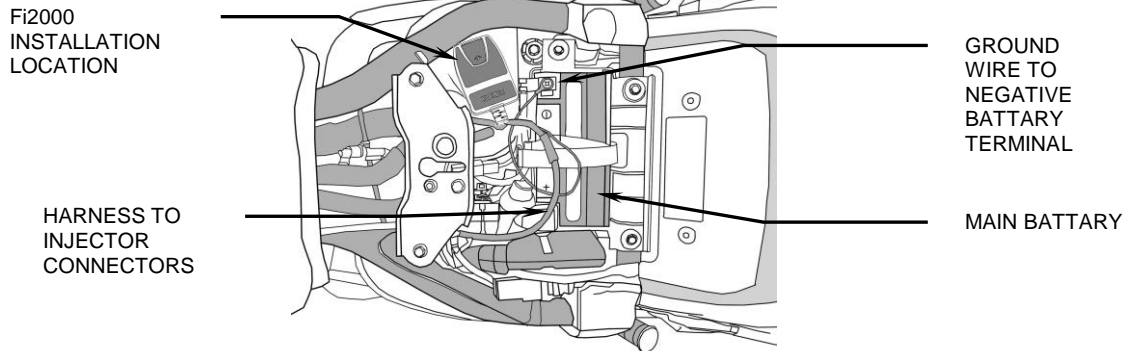

FIGURE 1

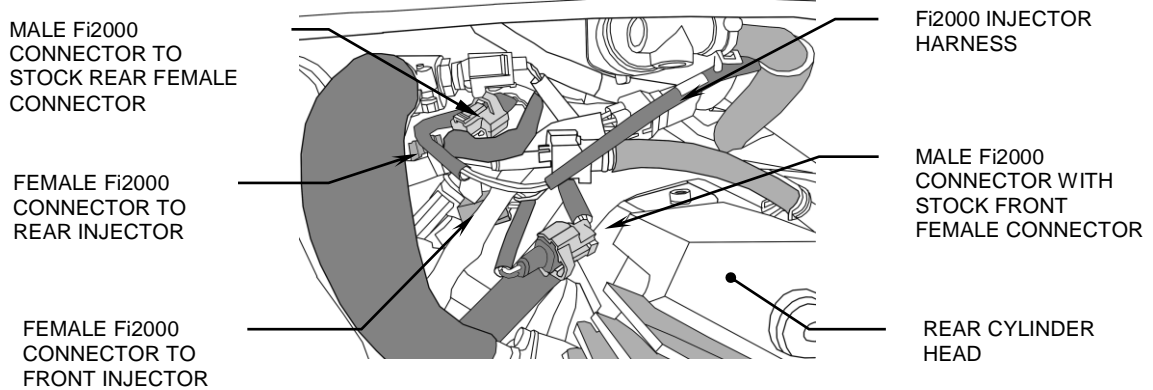

FIGURE 2

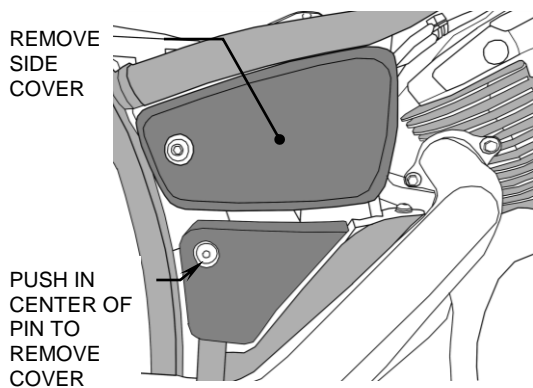

FIGURE 3

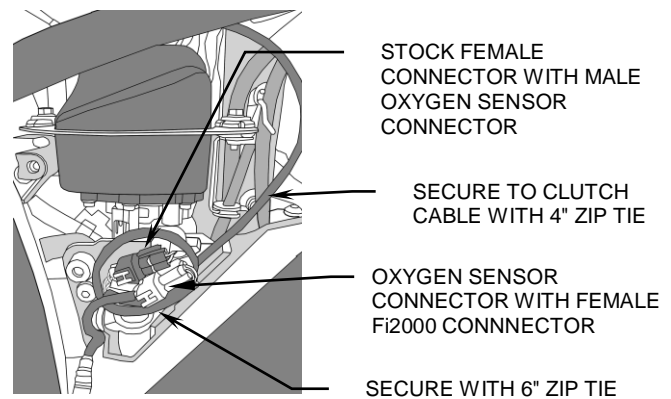

FIGURE 4

DISCLAIMER: NOT LEGAL FOR SALE OR USE IN CALIFORNIA ON ANY POLLUTION CONTROLLED MOTOR VEHICLES. Tech Support <https://fi2000.com>