

Items Supplied >

- 1 – Powrpro Black Fuel Injection Module
- 2 – Zip Tie 6"
- 1 – Zip Tie 12"
- 1 – .75" Plastic Plug
- 1 – Velcro Strip

Application(s) >

YAMAHA ROADSTAR XV1700
2008-2014

Instruction Manual >

92-1771B

Page 1 of 4

Read all instructions carefully and completely before installing your new POWRPRO module. It is recommended that a qualified mechanic or technician install this product. Before installing it is recommended that the fuel tank be low on fuel.

1. Remove the seat by turning the ignition key entirely to the left side. Then first remove the painted left then right hand side cover from behind the engine, secured with large button head screws on each side. There is a M6 Hex screw hidden between the covers, which must be removed before removing the right cover.
2. Remove the three buttonhead screws retaining the instrument cluster on top of the fuel tank, once the bezel is free disconnect the two harness connectors located just to the front of the fuel tank, remove the bezel entirely to prevent it from scratching the fuel tank.
3. Remove the 10mm Cap nut and bolt retaining the rear of the fuel tank. Once removed, prop the rear of the fuel tank up with a block, to gain access to the top of the engine area and six-pin fuel injector connector.
4. Position the Fi2000 to the rear of the tool kit on the flat frame member (under the seat) and feed the six pin connector harness around the right side frame rail, and up underneath the fuel tank, locate the stock six pin connector on top of the fuel injector area, disconnect it by prying up the tab on the female connector. Once disconnected, mate the corresponding male and female Fi2000 connectors with the stock connectors, be sure they seat firmly when pressed together, see Figure 1.
5. Route the two oxygen sensor harnesses along the upper right frame rail, and then underneath it directly behind the oil fill neck and ground connection, see Figure 2. Route both connectors behind the insulated relay cover; you may need to pull it outward slightly, to fit the harnesses behind it.
6. Locate the rear oxygen sensor connector mounted on the side of the relay cover. On the female connector pull the retaining tang outward to release the male connector. Insert the corresponding male and female Fi2000 connectors into the stock connectors from the shorter of the two oxygen sensor harnesses, be sure the connectors seat properly when pressed together. Tuck the excess harness beneath the relay cover; see Figure 2.
7. Route the longer Fi2000 oxygen sensor harness, along the right rear frame rail, just in front of the swing arm, continue routing it along the lower frame rail forward toward the front stock oxygen sensor connector. Disconnect the stock oxygen sensor connector, and mate the corresponding Fi2000 male and female connectors to it, be sure they seat properly when pressed together, see Figure 3.
8. On the front oxygen sensor harness, pull any extra slack out of it back towards the insulated relay cover. Install two 6" zip ties along the frame rail as indicated in Figure 4, to prevent the harness from getting too close to the exhaust.
9. On the fuel injector harness, pull any slack out of it back toward the Fi2000 housing, and install one 12" ziptie around the harness and frame neck, trim off excess zip tie, see Figure 5.
10. Locate the air injection pump and inlet hose at the front of the engine on the right side. To prevent sever trailing throttle backfiring, install the supplied 0.75" plug into the air inlet hose, see Figure 6, push plug in until flush.

DISCLAIMER: NOT LEGAL FOR SALE OR USE IN CALIFORNIA ON ANY POLLUTION CONTROLLED MOTOR VEHICLES.

11. Remove the socket head screw retaining the ground wire to the oil fill neck, and attach the Fi2000 ground wire to the same location, reinstall the screw and tighten securely, see Figure 7.
12. Remove the block supporting the fuel tank, and lower it back into place, reinstall the 10mm cap nut and screw, and tighten securely.
13. Reconnect the two instrument bezel connectors and reinstall the 3-buttonhead screws securing it.
14. Verify that the module has power and connections have been made correctly; watch the clear window on the FI housing and turn "ON" the key ignition and set the handlebar run switch to "ON", confirm that the Red LED turns on. On some models the Red light will turn off after 4-5 seconds as the fuel pump cycles off, which is OK. If you do not see a Red light, it may be necessary to wait for the alarm to reset (if applicable) and try again. Also confirm the side stand is up, bike is in neutral, and clutch is in. Start the bike and confirm the LED remains on solid Red. **NOTE:** Make sure ignition is turned off before attempting to change any Fi2000 harness connections if no Red light is seen. For access to the Blue Tooth Tuning App on the module, please download the Fi2000 App to your smart device, Android 4.3 & later or Apple iOS 5.0 & later operating systems. Once the app is installed, make sure the motorcycle is in neutral and start the engine, use the connect button within the app and the Blue light on the Fi module window will light up during pairing connection and remain solid Blue while paired and connected with respective Android or Apple Device. Once the app has been used and settings saved and disconnected through the app, the Blue light will turn off, and the PowrPro Black will be ready for continued service on the motorcycle.
15. Once it has been confirmed that the Fi2000 is functioning properly, remove the double sticky tape from the Velcro on the back of the Fi2000 Module and attach it in place on the flat frame rail, where it was previously resting, as in Figure 7. Install the side covers and tighten all screws/bolts securely, install the seat and confirm all removed or loosened components have been reinstalled properly.

MALE Fi2000
CONNECTOR

ROADSTAR
FEMALE
CONNECTOR

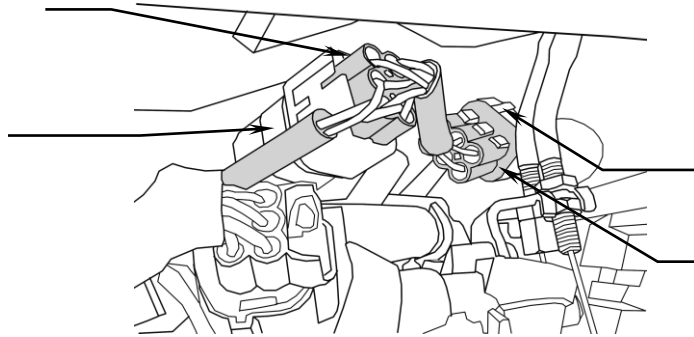

ROADSTAR
MALE
CONNECTOR

FEMALE
Fi2000
CONNECTOR

FIGURE 1

INSULATED RELAY
COVER ON RIGHT SIDE
BEHIND ENGINE, SIDE
COVER MUST BE
REMOVED TO GAIN
ACCESS

ROADSTAR REAR
FEMALE O₂ SENSOR
CONNECTOR

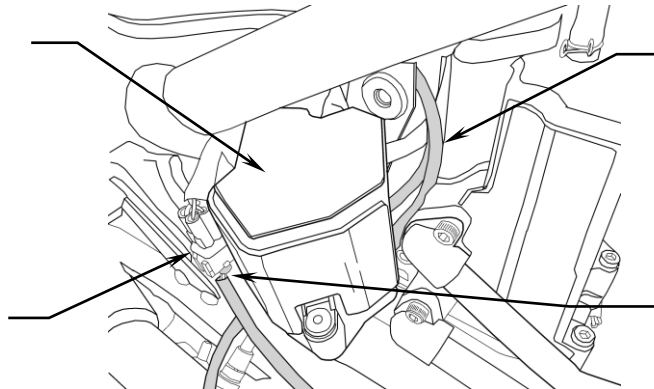

HARNESS ROUTED
BEHIND INSULATED
RELAY COVER

REAR MALE Fi2000 O₂
CONNECTOR

FIGURE 2

FEMALE Fi2000
O₂ CONNECTOR
WITH STOCK
MALE O₂
CONNECTOR

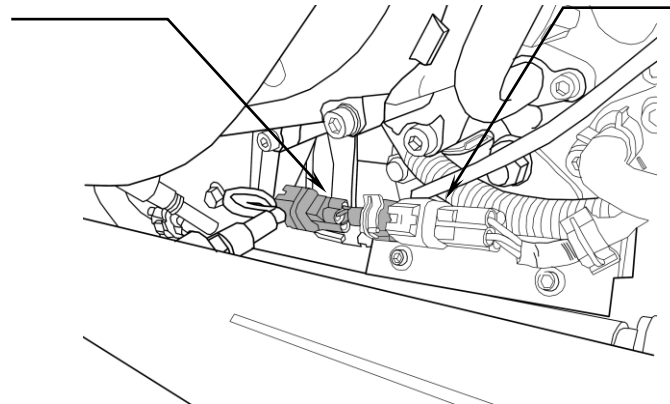

STOCK FEMALE
CONNECTOR WITH
MALE Fi2000
CONNECTOR

FIGURE 3

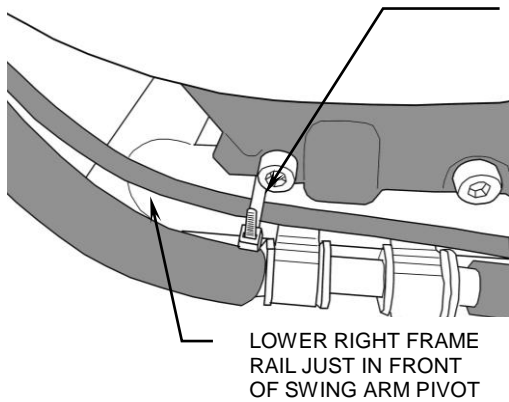

ZIP TIE
SECURING
FRONT O₂
FI2000
HARNESS

ZIP TIE
SECURING
FRONT O₂
SENSOR
HARNESS
AT FRONT

LOWER RIGHT FRAME
RAIL JUST IN FRONT
OF SWING ARM PIVOT

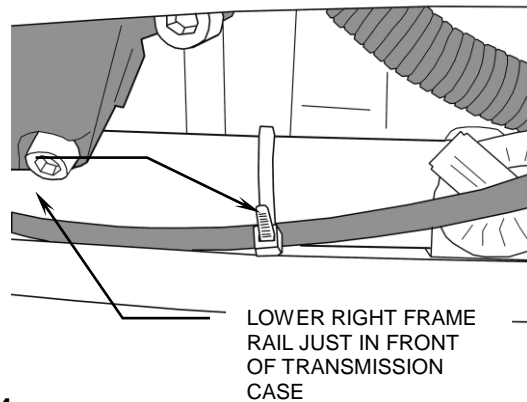

LOWER RIGHT FRAME
RAIL JUST IN FRONT
OF TRANSMISSION
CASE

FIGURE 4

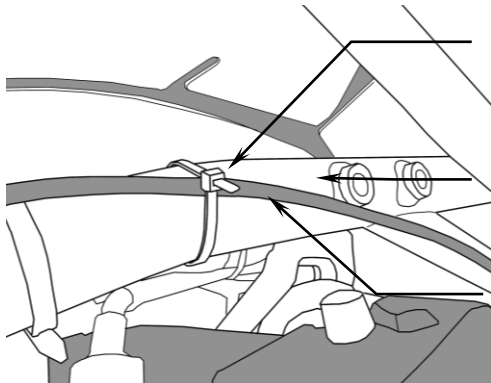

12" ZIP TIE
TRIMMED
AFTER
INSTALLATION

TOP FRAME
RAIL UNDER
FUEL TANK

FI2000 FUEL
INJECTOR
HARNESS

AIR
INJECTION
INLET
HOSE

ENGINE
FRONT
CYLINDER

.75" PLUG
INSTALLED
HERE

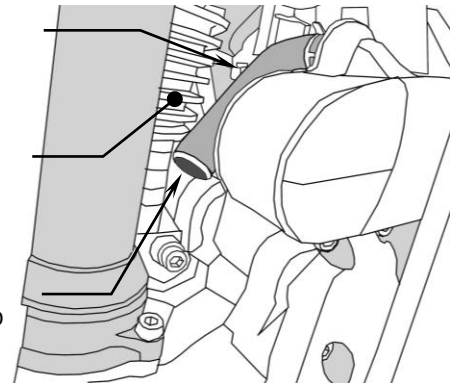
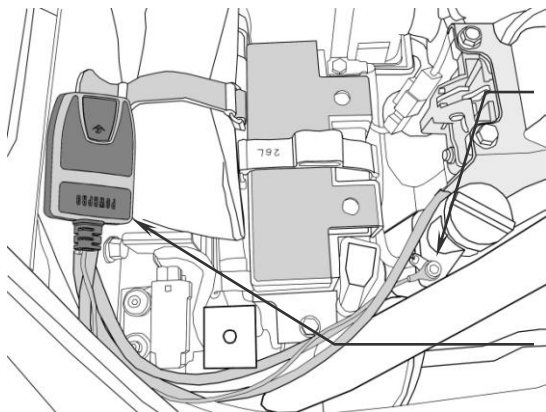

FIGURE 5

FIGURE 6



GROUND
WIRE
FASTENING
LOCATION

FI2000
INSTALLATION
LOCATION

FIGURE 7

DISCLAIMER: NOT LEGAL FOR SALE OR USE IN CALIFORNIA ON ANY POLLUTION CONTROLLED MOTOR VEHICLES. Tech Support <https://fi2000.com>