

## Items Supplied >

- 1 – Powrpro Black Fuel Injection Module
- 1 – Zip Tie, (1): 3/16" x 8"
- 2 – Zip Tie, (2): 3/16" x 6"
- 1 – Velcro Strip

## Application(s) >

- |                          |       |
|--------------------------|-------|
| Yamaha V-Star 950/Tourer | 09-22 |
| Yamaha Bolt              | 09-22 |

## Instruction Manual >

92-1775B

Page 1 of 2

**Read all instructions carefully and completely before installing your new POWRPRO module. It is recommended that a qualified mechanic or technician install this product. Before installing it is recommended that the gas tank be low on fuel.**

1. Remove the seat. Remove the allen bolts securing the rear of the fuel tank, prop the tank up securely to allow access to the fuel injector connectors.
2. Position the Fi2000 module in the designated area under the seat, see Figure 1. Then feed the Fi2000 harness with the injector connectors forward until reaching the intake manifold area.
3. Locate the stock fuel injector for the front cylinder under the fuel tank on the left side of the motorcycle, see Figure 2. Unplug the stock connector and using the forward pair of Fi2000 injector connectors, plug each male and female connector into the corresponding stock connectors. Repeat for rear fuel injector using the rear pair of Fi2000 injector connectors. Tuck the connectors and harness wires out of the way and lower the fuel tank.
4. Route the second harness with the O<sub>2</sub> connector through the designated space/hole next to the battery tray until the connector ends appear out of the bottom of the motorcycle, See Figure 1. Unplug the stock O<sub>2</sub> connector that is mounted above the right side lower frame rail. Replace this connection with the corresponding Fi2000 O<sub>2</sub> male and female connectors into the stock connectors, see Figure 3. Zip tie loose wiring to the frame away from the exhaust pipes.
5. Velcro the Fi2000 module to the top of the white fuse box, see Figure 1. Attach the ground wire from the Fi2000 to the negative post. Before reinstalling the seat, verify connections.
6. Verify that the module has power and connections have been made correctly; watch the clear window on the FI housing and turn "ON" the key ignition and set the handlebar run switch to "ON", confirm that the Red LED turns on. On some models the Red light will turn off after 4-5 seconds as the fuel pump cycles off, which is OK. If you do not see a Red light, it may be necessary to wait for the alarm to reset (if applicable) and try again. Also confirm the side stand is up, bike is in neutral, and clutch is in. Start the bike and confirm the LED remains on solid Red. **NOTE:** Make sure ignition is turned off before attempting to change any Fi2000 harness connections if no Red light is seen. For access to the Blue Tooth Tuning App on the module, please download the Fi2000 App to your smart device, Android 4.3 & later or Apple iOS 5.0 & later operating systems. Once the app is installed, make sure the motorcycle is in neutral and start the engine, use the connect button within the app and the Blue light on the Fi module window will light up during pairing connection and remain solid Blue while paired and connected with respective Android or Apple Device. Once the app has been used and settings saved and disconnected through the app, the Blue light will turn off, and the PowrPro Black will be ready for continued service on the motorcycle.

**DISCLAIMER: NOT LEGAL FOR SALE OR USE IN CALIFORNIA ON ANY POLLUTION CONTROLLED MOTOR VEHICLES.**

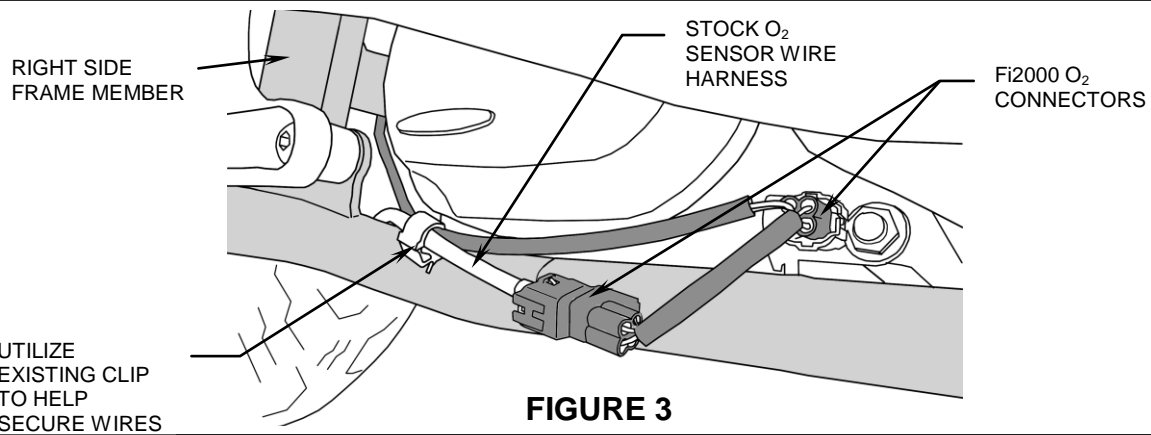
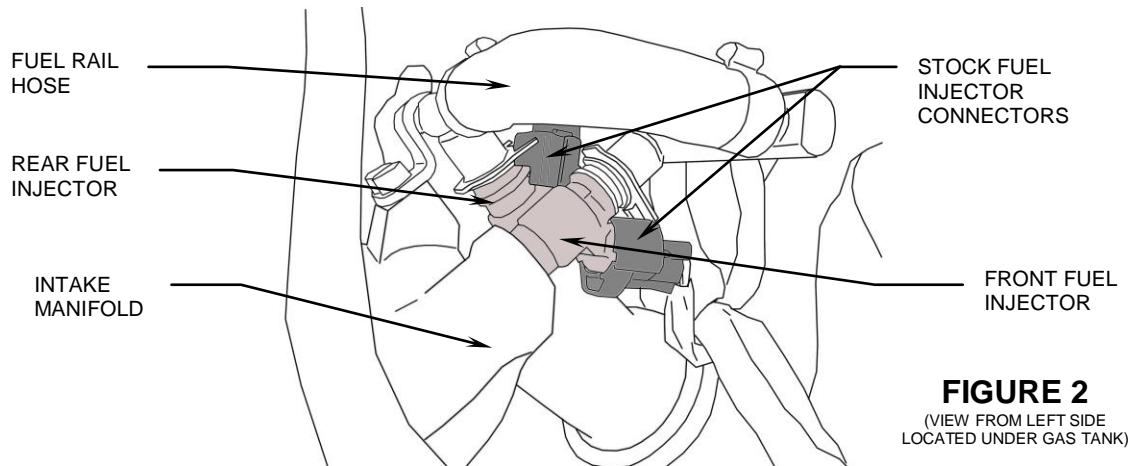
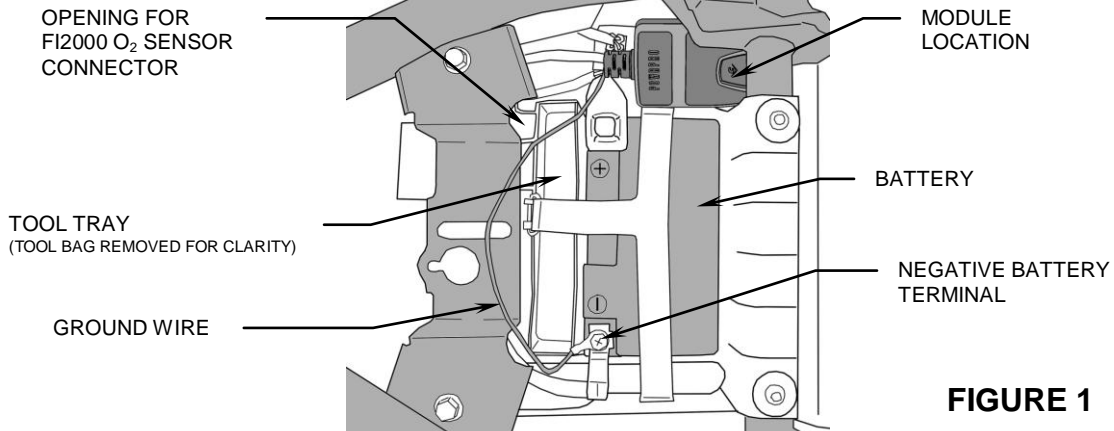

**DISCLAIMER:** NOT LEGAL FOR SALE OR USE IN CALIFORNIA ON ANY POLLUTION CONTROLLED MOTOR VEHICLES. Tech Support <https://fi2000.com>